

DSCI, LLC

TEXAS D.P.U.C. TARIFF NO. 1

REGULATIONS AND SCHEDULE OF INTRASTATE CHARGES
APPLYING TO COMMUNICATIONS ACCESS SERVICES WITHIN

THE STATE OF TEXAS

This tariff contains the rates, charges, terms and conditions of service applicable to the furnishing of telecommunications services provided by DSCI, LLC (“DSCI”) with a principal office at 303 Wyman Street, Suite 350, Waltham, MA 02451. This Tariff applies to services provided within the State of Texas. This tariff is on file with the Texas Department of Public Utility Commission, where copies may be inspected during normal business hours at the Company’s place of business.

Issued: August 12, 2014

Effective: September 1, 2014

Issued By:

Sean Dandley, CEO/President
303 Wyman Street Suite 350
Waltham, MA, 02451

APPLICATION OF TARIFF

This tariff sets forth the service offerings, rates, terms and conditions applicable to the provision of competitive local exchange service and long distance telecommunications services by DSCI, LLC (“DSCI”), hereinafter referred to as the Company, to Customers within the State of Texas. DSCI’s services are furnished subject to the availability of facilities and subject to the terms and conditions set forth herein.

This tariff is on file with the Texas Public Utilities Commission. In addition, this tariff is available for review at the main office of DSCI, LLC, at 303 Wyman Street, Suite 450, Waltham, Massachusetts 02452.

Issued: August 12, 2014

Effective: September 1, 2014

Issued By:

Sean Dandley, CEO/President
303 Wyman Street Suite 350
Waltham, MA, 02451

TABLE OF CONTENTS

Application of Tariff..... 2
 TABLE OF CONTENTS..... 3
 CHECK SHEET..... 5
 EXPLANATION OF CHANGE SYMBOLS..... 6
 TARIFF FORMAT..... 7
 DEFINITIONS..... 8
 RULES & REGULATIONS..... 12
 UNDERTAKING OF THE COMPANY..... 12
 SCOPE..... 12
 SHORTAGE OF FACILITIES..... 12
 LIMITATIONS ON LIABILITY.....15
 NOTIFICATION OF SERVICE-AFFECTING ACTIVITIES.....19
 PROVISION OF EQUIPMENT AND FACILITIES.....20
 NON-ROUTINE INSTALLATION..... 21
 SPECIAL CONSTRUCTION..... 21
 OWNERSHIP OF FACILITIES..... 22
 PROHIBITED USES..... 22
 OBLIGATIONS OF THE CUSTOMER-GENERAL.....23
 OBLIGATIONS OF THE CUSTOMER-LIABILITY OF THE CUSTOMER..... 25
 CUSTOMER EQUIPMENT & CHANNELS.....26
 CUSTOMER EQUIPMENT & CHANNELS-GENERAL.....26
 CUSTOMER EQUIPMENT & CHANNELS- STATION EQUIPMENT.....26
 CUSTOMER EQUIPMENT & CHANNELS- INTERCONNECTION OF FACILITIES.....27
 CUSTOMER EQUIPMENT & CHANNELS- INSPECTIONS.....28
 PAYMENT ARRANGEMENTS..... 29
 PAYMENT ARRANGEMENTS-PAYMENT FOR SERVICE.....29
 PAYMENT ARRANGEMENTS-BILLING AND COLLECTION OF CHARGES.....29
 PAYMENT ARRANGEMENTS-DISPUTED INVOICES.....31
 PAYMENT ARRANGEMENTS-ADVANCE PAYMENTS.....31
 PAYMENT ARRANGEMENTS-DEPOSITS.....32
 PAYMENT ARRANGEMENTS-DISCONTINUANCE OF SERVICE.....34
 PAYMENT ARRANGEMENTS-CANCELATION OF APPLICATION FOR SERVICE.....36
 PAYMENT ARRANGEMENTS-CHANGES IN SERVICES REQUESTED..... 36
 PAYMENT ARRANGEMENTS-ALLOWANCES FOR INTERRUPTIONS IN SERVICE.....36
 CANCELLATION FOR SERVICE INTERRUPTION.....37
 USE OF CUSTOMERS SERVICE BY OTHERS.....39
 CANCELLATION OF SERVICE/TERMINATION LIABILITY.....41
 TRANSFERS AND ASSIGNMENTS..... 41
 CUSTOMER LIABILITY FOR UNAUTHORIZED USE OF THE NETWORK 42
 CUSTOMER LIABILITY FOR FRAUD AND UNAUTHORIZED USE OF THE NETWORK..... 42
 NOTICES AND COMMUNICATIONS 43
 TAXES, FEES AND SURCHARGES 43
 MISCELLANEOUS PROVISIONS 44

Issued: August 12, 2014

Effective: September 1, 2014

Issued By: Sean Dandley, CEO/President
 303 Wyman Street Suite 350
 Waltham, MA, 02451

TABLE OF CONTENTS (CONT'D)

DESCRIPTION OF SERVICE AND RATES	45
SERVICES OFFERINGS	47
BASIC TOLL FREE SERVICE	49
LOCAL EXCHANGE SERVICE	49
LOCAL DIAL TONE SERVICE	49
LOCAL SERVICE PACKAGES	54
SWITCHED SERVICES	57
MISCELLANEOUS	58
RATES	58

Issued: August 12, 2014

Effective: September 1, 2014

Issued By:

Sean Dandley, CEO/President
303 Wyman Street Suite 350
Waltham, MA, 02451

CHECK SHEET

The title page and all sheets included in this tariff are effective as of the date shown. Original and revised sheets, as named below, comprise all changes from the original tariff in effect.

Section	Page	Revision	Section	Page	Revision
1	Title	Original	3	1	Original
1	1	Original	3	2	Original
1	2	Original	3	3	Original
1	3	Original	3	4	Original
1	4	Original	3	5	Original
1	5	Original	3	6	Original
1	6	Original	3	7	Original
1	7	Original	3	8	Original
2	1	Original	3	9	Original
2	2	Original			
2	3	Original			
2	4	Original			
2	5	Original			
2	6	Original			
2	7	Original			
2	8	Original			
2	9	Original			
2	10	Original			
2	11	Original			
2	12	Original			
2	13	Original			
2	14	Original			
2	15	Original			
2	16	Original			
2	17	Original			
2	18	Original			
2	19	Original			
2	20	Original			
2	21	Original			
2	22	Original			
2	23	Original			

Issued: August 12, 2014

Effective: September 1, 2014

Issued By:

Sean Dandley, CEO/President
303 Wyman Street Suite 350
Waltham, MA, 02451

**EXPLANATION OF
SYMBOLS**

- (C) To signify changed listing, rule, or condition which may affect rates or charges.
- (D) To signify discontinued material, including listing, rate, rule, or condition.
- (I) To signify an increase.
- (M) To signify material relocated from or to another part of tariff schedule with no change in text, rate, rule or condition.
- (N) To signify new material including listing, rate, rule or condition.
- (R) To signify reduction.
- (S) To signify reissued material.
- (T) To signify change in wording of text but not change in rate, rule, or condition.

Issued: August 12, 2014

Effective: September 1, 2014

Issued By:

Sean Dandley, CEO/President
303 Wyman Street Suite 350
Waltham, MA, 02451

TARIFF FORMAT

A. Page Numbering – Page numbers appear in the upper right corner of the page. Pages are numbered sequentially. However, new pages are occasionally added to the tariff. When a new page is added between pages already in effect, a decimal is added. For example, a new page added between pages 14 and 15 would be 14.1.

B. Page Revision Numbers – Revision numbers also appear in the upper right corner of each page. These numbers are used to determine the most current page version on file with the Commission. For example, the 4th revised Page 14 cancels the 3rd revised Page 14. Because of various suspension periods, deferrals, etc., the most current page number on file with the Commission is not always the tariff page in effect. Consult the Check Sheet for the page currently in effect.

C. Paragraph Numbering Sequence – There are nine levels of paragraph coding. Each level of coding is subservient to its next higher level:

- 2.
- 2.1.
- 2.1.1.
- 2.1.1.A.
- 2.1.1.A.1.
- 2.1.1.A.1.(a).
- 2.1.1.A.1.(a).I.
- 2.1.1.A.1.(a).I.(i).
- 2.1.1.A.1.(a).I.(i).(1).

D. Check Sheets – When a tariff filing is made with the Commission, an updated Check Sheet accompanies the tariff filing. The Check Sheet lists the pages contained in the tariff, with a cross reference to the current revision number. When new pages are added, the Check Sheet is changed to reflect the revision. All revisions made in a given filing are designated by an asterisk (*). There will be no other symbols used on this page if these are the only changes made to it (i.e., the format, etc., remain the same, just revised revision levels on some pages). The tariff user should refer to the latest Check Sheet to find out if a particular page is the most current on file with the Commission.

Issued: August 12, 2014

Effective: September 1, 2014

Issued By:

Sean Dandley, CEO/President
303 Wyman Street Suite 350
Waltham, MA, 02451

SECTION 1 – DEFINITIONS

Access Line – An arrangement from a local exchange telephone company or other common carrier, using either dedicated or switched access, which connects a Customer’s location to Carrier’s location or switching center.

Account – A Company accounting category containing up to two (2) residential local exchange access lines billed to the same Customer at the same address. The second or non-primary local exchange access line will share any call allowance of the primary local exchange access line. The second or non-primary local exchange access line, therefore, will not be provisioned to include a separate call allowance structure. No features are provided with the second or non-primary local exchange access line.

Account Codes – Permits Centrex Stations and attendants to dial an account code number of up to eight digits. For use when placing calls over facilities arranged for Automatic Message Accounting (AMA) recording. The account or project number must be input prior to dialing the called number.

Advance Payment – Part or all of a payment required before the start of service.

Authorization Code – A numerical code, one or more of which may be assigned to a Customer, to enable Carrier to identify the origin of service of the Customer so it may rate and bill the call. All authorization codes shall be the sole property of Carrier and no Customer shall have any property or any other right or interest in the use of any particular authorization code. Automatic numbering identification (ANI) may be used as or in connection with the authorization code.

Authorized User – A person, firm or corporation authorized by the Customer to be an end-user of the service of the Customer.

Automatic Numbering Identification (ANI) – A type of signaling provided by a local telephone company which automatically identifies the local exchange line from which a call originates.

Commission – Texas Public Utilities Commission.

Common Carrier – An authorized company or entity providing telecommunications services to the public. Company – DSCI, LLC, the issuer of this tariff.

Customer – The person, firm or corporation that orders service and is responsible for payment of charges and compliance with the terms and conditions of this tariff.

Customer Premises – A location designated by the Customer for the purposes of connecting to the Company’s services.

Issued: August 12, 2014

Effective: September 1, 2014

Issued By:

Sean Dandley, CEO/President
303 Wyman Street Suite 350
Waltham, MA, 02451

SECTION 1 – DEFINITIONS (CONT'D)

Customer Terminal Equipment – Terminal equipment provided by the Customer

Deposit – Refers to a cash or equivalent of cash security held as a guarantee for payment of the charges.

End Office – The LEC switching system office or serving wire center where Customer station loops are terminated for purposes of interconnection to each other and/or to trunks.

Equal Access – A form of dialed access provided by local exchange companies whereby interexchange calls dialed by the Customer are automatically routed to the Company's network. Presubscribed Customers may also route interexchange calls to the Company's network by dialing an access code supplied by the Company.

Exchange Telephone Company or Telephone Company – Denotes any individual, partnership, association, joint-stock company, trust, or corporation authorized by the appropriate regulatory bodies to engage in providing public switched communication service throughout an exchange area, and between exchange areas within the LATA.

ICB – Individual Case Basis.

IXC or Interexchange Carrier – A long distance telecommunications service provider.

Interruption – The inability to complete calls due to equipment malfunctions or human errors. Interruption shall not include, and no allowance shall be given for service difficulties such as slow dial tone, circuits busy or other network and/or switching capability shortages. Nor shall Interruption include the failure of any service or facilities provided by a common carrier or other entity other than the Carrier. Any interruption allowance provided within this Tariff by Carrier shall not apply where service is interrupted by the negligence or willful act of the Customer, or where the Carrier, pursuant to the terms of this Tariff, terminates service because of non-payment of bills, unlawful or improper use of the Carrier's facilities or service, or any other reason covered by this Tariff or by applicable law.

LATA – A Local Access and Transport Area established pursuant to the Modification of Final Judgment entered by the United States District Court for the District of Columbia in Civil Action No. 82-0192; or any other geographic area designed as a LATA in the National Exchange Carrier Association, Inc. Tariff F.C.C. No. 4, or its successor tariff(s).

LEC – Local Exchange Company refers to the dominant, monopoly local telephone company in the area also served by the Company.

Issued: August 12, 2014

Effective: September 1, 2014

Issued By:

Sean Dandley, CEO/President
303 Wyman Street Suite 350
Waltham, MA, 02451

SECTION 1 – DEFINITIONS (CONT'D)

Monthly Recurring Charges – The monthly charges to the Customer for services, facilities and equipment, which continue for the agreed upon duration of the service.

MOU – Minutes of Use.

NECA – National Exchange Carriers Association.

Non-Recurring Charge (“NRC”) – The initial charge, usually assessed on a one-time basis, to initiate and establish service

PBX – Private Branch Exchange.

PIN – Personal Identification Number. See Authorization

Code. Point of Presence (“POP”) – Point of Presence.

Recurring Charges – Monthly charges to the Customer for services, and equipment, which continues for the agreed- upon duration of the service.

Service – Any means of service offered herein or any combination thereof.

Service Order – The written request for Company services executed by the Customer and the Company in the format devised by the Company. The signing of a Service Order Form by the Customer and acceptance by the Company initiates the respective obligations of the parties as set forth therein and pursuant to this tariff.

Serving Wire Center – A specified geographic point from which the vertical and horizontal coordinate is used in calculation of airline mileage.

Shared Inbound Calls – Refers to calls that are terminated via the Customer’s Company-provided local exchange line.

Issued: August 12, 2014

Effective: September 1, 2014

Issued By:

Sean Dandley, CEO/President
303 Wyman Street Suite 350
Waltham, MA, 02451

SECTION 1 – DEFINITIONS (CONT'D)

Shared Outbound Calls – Refers to calls in Feature Group (FGD) exchanges whereby the Customer's local telephone lines are presubscribed by the Company to the Company's outbound service such that "1 + 10-digit number" calls are automatically routed to the Company's or an IXC's network. Calls to stations within the Customer's LATA may be placed by dialing "10XXX" or 101XXXX" with a "1+10-digit number."

Station – The network control signaling unit and any other equipment provided at the Customer's premises which enables the Customer to establish communications connections and to effect communications through such connections.

Subscriber – The person, firm, partnership, corporation, or other entity who orders telecommunications service from DSCI. Service may be ordered by, or on behalf of, those who own, lease or otherwise manage the pay telephone, PBX, or other switch vehicle from which an End User places a call utilizing the services of the Company.

Switched Access Origination/Termination – Where access between the Customer and the interexchange carrier is provided on local exchange company Feature Group circuits and the connection to the Customer is a LEC-provided business or residential access line. The cost of switched Feature Group access is billed to the interexchange carrier.

Terminal Equipment – Any telecommunications equipment other than the transmission or receiving equipment installed at a Company location.

Usage Charges – Charges for minutes or messages traversing over local exchange facilities.

User or End User – A Customer, Joint User or any other person authorized by a Customer to use service provided under this tariff.

Issued: August 12, 2014

Effective: September 1, 2014

Issued By:

Sean Dandley, CEO/President
303 Wyman Street Suite 350
Waltham, MA, 02451

SECTION 2 – RULES AND REGULATIONS**Undertaking of the Company****Scope**

The Company undertakes to furnish communications service pursuant to the terms of this tariff in connection with one-way and/or two-way information transmission between points within the State of Texas.

The Company is responsible under this tariff only for the services and facilities provided hereunder, and it assumes no responsibility for any service provided by any other entity that purchases access to the Company network in order to originate or terminate its own services, or to communicate with its own customers.

Shortage of Equipment or Facilities

- A. The Company reserves the right to limit or to allocate the use of existing facilities or of additional facilities offered by the Company, when necessary because of lack of facilities, or due to some other cause beyond the Company's control. The furnishing of service under this tariff is subject to the availability on a continuing basis of all the necessary facilities and is limited to the capacity of the Company's facilities as well as facilities the Company may obtain from other carriers to furnish service from time to time as required at the sole discretion of the Company.

Issued: August 12, 2014

Effective: September 1, 2014

Issued By:

Sean Dandley, CEO/President
303 Wyman Street Suite 350
Waltham, MA, 02451

SECTION 2 – RULES AND REGULATIONS (CONT'D)**Undertaking of the Company (Cont'd)****Terms and Conditions**

- A. Service is provided on the basis of a minimum period of at least thirty (30) days, 24 hours per day. For the purpose of computing charges in this tariff, a month is considered to have 30 days.
- B. Except as otherwise stated in this tariff, Customers may be required to enter into written service orders which shall contain or reference a specific description of the service ordered, the rates to be charged, the duration of the services, and the terms and conditions in this tariff. Customers will also be required to execute any other documents as may be reasonably requested by the Company.
- C. At the expiration of the initial term specified in each Service Order, or in any extension thereof, service shall continue on a month-to-month basis at the then current rates unless terminated by either party upon notice. Any termination shall not relieve the Customer of its obligation to pay any charges incurred under the service order and this tariff prior to termination. The rights and obligations which by their nature extend beyond the termination of the term of the service order shall survive such termination.
- D. In any action between the parties to enforce any provision of this tariff, the prevailing party shall be entitled to recover its legal fees and court costs from the non-prevailing party in addition to other relief a court may award.
- E. Service may be terminated upon written notice to the Customer if:
 - 1. the Customer is using the service in violation of the tariff; or
 - 2. the Customer is using the service in violation of the law.
- F. This tariff shall be interpreted and governed by the laws of the State of Texas regardless of its choice of laws provision.
- G. Any other Telephone Company may not interfere with the right of any person or entity to obtain service directly from the Company. No person or entity shall be required to make any payment, incur any penalty, monetary or otherwise, or purchase any services in order to have the right to obtain service directly from the Company.

Issued: August 12, 2014

Effective: September 1, 2014

Issued By:

Sean Dandley, CEO/President
303 Wyman Street Suite 350
Waltham, MA, 02451

SECTION 2 – RULES AND REGULATIONS (CONT'D)

- H. To the extent that either the Company or any other telephone company exercises control over available cable pairs, conduit, duct space, raceways, or other facilities needed by the other to reach a person or entity, the party exercising such control shall make them available to the other on terms equivalent to those under which the Company makes similar facilities under its control available to its customers. At the reasonable request of either party, the Company and the other telephone company shall join the attempt to obtain from the owner of the property access for the other party to serve a person or entity.

Issued: August 12, 2014

Effective: September 1, 2014

Issued By:

Sean Dandley, CEO/President
303 Wyman Street Suite 350
Waltham, MA, 02451

SECTION 2 – RULES AND REGULATIONS (CONT'D)**Undertaking of the Company (Cont'd)****Limitations on Liability**

- A. Except as otherwise stated in this section, the liability of the Company for damages arising out of either: (1) the furnishing of its services, including, but not limited to, mistakes, omissions, interruptions, delays, or errors, or other defects, representations, or use of these services; or (2) the failure to furnish its service, whether caused by acts or omission, shall be limited to the extension of allowances to the Customer for interruptions in service as set forth in Section 2.6.
- B. Except for the extension of allowances to the Customer for interruptions in service as set forth in Section 2.6, the Company shall not be liable to a Customer or third party for any direct, indirect, special, incidental, reliance, consequential, exemplary or punitive damages, including, but not limited to, loss of revenue or profits, for any reason whatsoever, including, but not limited to, any act or omission, failure to perform, delay, interruption, failure to provide any service or any failure in or breakdown of facilities associated with the service.
- C. The liability of the Company for errors in billing that results in overpayment by the Customer shall be limited to a credit equal to the dollar amount erroneously billed or, in the event that payment has been made and service has been discontinued, to a refund of the amount erroneously billed.
- D. The Company shall be indemnified and saved harmless by the Customer from and against all loss, liability, damage and expense, including reasonable counsel fees, due to:
1. Any act or omission of: (a) the Customer;(b) any other entity furnishing service, equipment or facilities for use in conjunction with services or facilities provided by the Company; or (c) common carriers or warehousemen, except as contracted by the Company;
 2. Any delay or failure of performance or equipment due to causes beyond the Company's control, including but not limited to, acts of God, fires, floods, earthquakes, hurricanes, or other catastrophes; national emergencies, insurrections, riots, wars or other civil commotions; strikes, lockouts, work stoppages or other labor difficulties; criminal actions taken against the Company; unavailability, failure or malfunction of equipment or facilities provided by the Customer or third parties; and any law, order, regulation or other action of any governing authority or agency thereof;

Issued: August 12, 2014

Effective: September 1, 2014

Issued By:

Sean Dandley, CEO/President
303 Wyman Street Suite 350
Waltham, MA, 02451

SECTION 2 – RULES AND REGULATIONS (CONT'D)

3. Any unlawful or unauthorized use of the Company's facilities and services;
4. Libel, slander, invasion of privacy or infringement of patents, trade secrets, or copyrights arising from or in connection with the material transmitted by means of Company- provided facilities or services; or by means of the combination of Company-provided facilities or services;
5. Breach in the privacy or security of communications transmitted over the Company's facilities;
6. Changes in any of the facilities, operations or procedures of the Company that render any equipment, facilities or services provided by the Customer obsolete, or require modification or alteration of such equipment, facilities or services, or otherwise affect their use or performance, except where reasonable notice is required by the Company and is not provided to the Customer, in which event the Company's liability is limited as set forth in paragraph A. of this Subsection 2.1.4;
7. Defacement of or damage to Customer premises resulting from the furnishing of services or equipment on such premises or the installation or removal thereof;
8. Injury to property or injury or death to persons, including claims for payments made under Workers' Compensation law or under any plan for employee disability or death benefits, arising out of, or caused by, any acts or omission of the Customer, or the construction, installation, maintenance, presence, use or removal of the Customer's facilities or equipment connected, or to be connected to the Company's facilities;

Issued: August 12, 2014

Effective: September 1, 2014

Issued By:

Sean Dandley, CEO/President
303 Wyman Street Suite 350
Waltham, MA, 02451

SECTION 2 – RULES AND REGULATIONS (CONT'D)**Undertaking of the Company (Cont'd)****Limitations on Liability (Cont'd)**

- D. (Cont'd)
9. Any non-completion of calls due to network busy conditions;
 10. Any calls not actually attempted to be completed during any period that service is unavailable;
 11. And any other claim resulting from any act or omission of the Customer or patron(s) of the Customer relating to the use of the Company's services or facilities.
- E. The Company does not guarantee nor make any warranty with respect to installations provided by it for use in an explosive atmosphere.
- F. The Company makes no warranties or representations, EXPRESS OR IMPLIED, either in fact or by operation of law, statutory or otherwise, including warranties of merchantability or fitness for a particular use, except those expressly set forth herein.
- G. Failure by the Company to assert its rights pursuant to one provision of this rate sheet does not preclude the Company from asserting its rights under other provisions.

Issued: August 12, 2014

Effective: September 1, 2014

Issued By:

Sean Dandley, CEO/President
303 Wyman Street Suite 350
Waltham, MA, 02451

SECTION 2 – RULES AND REGULATIONS (CONT'D)**Undertaking of the Company (Cont'd)****Limitations on Liability (Cont'd)**

- H. Directory Errors – In the absence of gross negligence or willful misconduct, no liability for damages arising from errors or mistakes in or omissions of directory listings, or errors or mistakes in or omissions of listing obtainable from the directory assistance operator, including errors in the reporting thereof, shall attach to the Company. An allowance for errors or mistakes in or omissions of published directory listings or for errors or mistakes in or omissions of listing obtainable from the directory assistance operator shall be at the monthly tariff rate for each listing, or in the case of a free or no-charge directory listing, credit shall equal two times the monthly tariff rate for an additional listing, for the life of the directory or the charge period during which the error, mistake or omission occurs.
- I. With respect to Emergency 911 Service:
1. This service is offered solely as an aid in handling assistance calls in connection with fire, police and other emergencies. The Company is not responsible for any losses, claims, demands, suits or any liability whatsoever, whether suffered, made, instituted or asserted by the Customer or by any other party or person for any personal injury or death of any person or persons, and for any loss, damage or destruction of any property, whether owned by the Customer or others, caused or claimed to have been caused by: (1) mistakes, omissions, interruptions, delays, errors or other defects in the provision of service, of (2) installation, operation, failure to operate, maintenance, removal, presence, condition, local or use of any equipment and facilities furnishing this service.
 2. Neither is the Company responsible for any infringement, nor invasion of the right of privacy of any person or persons, caused or claimed to have been caused directly or indirectly, by the installation, operation, failure to operate, maintenance, removal, presence, condition, occasion or use of emergency 911 service features and the equipment associated therewith, or by any services furnished by the Company, including, but not limited to the identification of the telephone number, address or name associated with the telephone used by the party or parties accessing emergency 911 service, and which arise out of the negligence or other wrongful act of the Company, its users, agencies or municipalities, or the employees or agents of any one of them.

Issued: August 12, 2014

Effective: September 1, 2014

Issued By:

Sean Dandley, CEO/President
303 Wyman Street Suite 350
Waltham, MA, 02451

SECTION 2 – RULES AND REGULATIONS (CONT'D)**Undertaking of the Company (Cont'd)****Limitations on Liability (Cont'd)**

- I. With respect to Emergency 911 Service (Cont'd)
 3. When a Customer with a non-published telephone number, as defined herein, places a call to the emergency 911 service, the Company will release the name and address of the calling party, where such information can be determined, to the appropriate local government authority responsible for emergency 911 service upon request of such governmental authority. By subscribing to service under this rate sheet, the Customer acknowledges and agrees with the release of information as described above.

Notification of Service-Affecting Activities

The Company will provide the Customer reasonable notification of service-affecting activities that may occur in normal operation of its business. Such activities may include, but are not limited to, equipment or facilities additions, removals or rearrangements and routine preventative maintenance. Generally, such activities are not specific to an individual Customer but affect many Customers' services. No specific advance notification period is applicable to all service activities. The Company will work cooperatively with the Customer to determine the reasonable notification requirements. With some emergency or unplanned service-affecting conditions, such as an outage resulting from cable damage, notification to the Customer may not be possible.

Issued: August 12, 2014

Effective: September 1, 2014

Issued By:

Sean Dandley, CEO/President
303 Wyman Street Suite 350
Waltham, MA, 02451

SECTION 2 – RULES AND REGULATIONS (CONT'D)**Undertaking of the Company (Cont'd)****Provision of Equipment and Facilities**

The Company shall use reasonable efforts to make available services to a Customer on or before a particular date, subject to the provisions of and compliance by the Customer with, the regulations contained in this tariff. The Company does not guarantee availability by any such date and shall not be liable for any delays in commencing service to any customer.

The Company shall use reasonable efforts to maintain only the facilities and equipment that it furnishes to the Customer. The Customer may not, nor may the Customer permit others to, rearrange, disconnect, remove, and attempt to repair, or otherwise interfere with any of the facilities or equipment installed by the Company, except upon the written consent of the Company.

The Company may substitute, change or rearrange any equipment or facility at any time and from time to time, but shall not thereby alter the technical parameters of the service provided by the Customer.

Equipment the Company provides or installs at the Customer Premises for use in connection with the services the Company offers shall not be used for any purpose other than that for which it was provided.

The Customer shall be responsible for the payment of service charges as set forth herein for visits by the Company's agents or employees to the Premises of the Customer when the service difficulty or trouble report results from the use of equipment or facilities provided by any other party other than the Company, including, but not limited to, the Customer.

The Company shall not be responsible for the installation, operation, or maintenance of any Customer-provided communications equipment. Where such equipment is connected to the facilities furnished pursuant to this tariff, the responsibility of the Company shall be limited to the furnishing of facilities offered under this tariff and to the maintenance and operation of such facilities. Subject to this responsibility, the Company shall not be responsible for:

- (1) the transmission of signals by Customer-provided equipment or for the quality of, or defects in, such transmission; or
- (2) the reception of signals by Customer-provided equipment.

Issued: August 12, 2014

Effective: September 1, 2014

Issued By:

Sean Dandley, CEO/President
303 Wyman Street Suite 350
Waltham, MA, 02451

SECTION 2 – RULES AND REGULATIONS (CONT'D)**Undertaking of the Company (Cont'd)****Non-routine Installation**

At the Customer's request, installation and/or maintenance may be performed outside the Company's regular business hours or in hazardous locations. In such cases, charges based on cost of the actual labor, material, or other costs incurred by or charged to the Company will apply. If installation is started during regular business hours but, at the Customer's request, extends beyond regular business hours into time periods including, but not limited to, weekends, holidays and/or night hours, additional hours may apply.

Special Construction

Subject to the agreement of the Company and to all of the regulations contained in this tariff, special construction of facilities may be undertaken on a reasonable efforts basis at the request of the Customer. Special construction is that construction undertaken:

- A. where facilities are not presently available, and there is no other requirement for the facilities so constructed;
- B. of a type other than that which the Company would normally utilize in the furnishing of its services;
- C. over a route other than that which the Company would normally utilize in the furnishing of its services;
- D. in a quantity greater than that which the Company would normally construct;
- E. on an expedited basis;
- F. on a temporary basis until permanent facilities are available;
- G. involving abnormal costs; or
- H. in advance of its normal construction.

Issued: August 12, 2014

Effective: September 1, 2014

Issued By:

Sean Dandley, CEO/President
303 Wyman Street Suite 350
Waltham, MA, 02451

SECTION 2 – RULES AND REGULATIONS (CONT'D)**Ownership of Facilities**

Title to all facilities provided in accordance with this tariff remains in the Company, its partners, agents, contractors or suppliers.

Prohibited Uses

The services the Company offers shall not be used for any unlawful purpose or for any use as to which the Customer has not obtained all required governmental approvals, authorizations, licenses, consents and permits.

The Company may require applicants for service who intend to use the Company's offerings for resale and/or for shared use to file a letter with the Company confirming that their use of the Company's offerings complies with relevant laws and Commission regulations, policies, orders, and decisions.

The Company may block any signals being transmitted over its Network by Customers which cause interference to the Company or other users. Customer shall be relieved of all obligations to make payments for charges relating to any blocked Service and shall indemnify the Company for any claim, judgment or liability resulting from such blockage.

A customer, joint user, or authorized user may not assign, or transfer in any manner, the service or any rights associated with the service without the written consent of the Company. The Company will permit a Customer to transfer its existing service to another entity if the existing Customer has paid all charges owed to the Company for regulated communications services. Such a transfer will be treated as a disconnection of existing service and installation of new service, and non-recurring installation charges as stated in this tariff will apply.

Issued: August 12, 2014

Effective: September 1, 2014

Issued By:

Sean Dandley, CEO/President
303 Wyman Street Suite 350
Waltham, MA, 02451

SECTION 2 – RULES AND REGULATIONS (CONT'D)**Obligations of the Customer****General**

The Customer is responsible for making proper application for service; placing any necessary order, complying with tariff regulations; payment of charges for services provided. Specific Customer responsibilities include, but are not limited to the following:

- A. the payment of all applicable charges pursuant to this tariff;
- B. damage to or loss of the Company's facilities or equipment caused by the acts of omissions of the Customer; or the noncompliance by the Customer, with these regulations; or by fire or theft or other casualty on the Customer Premises, unless caused by the negligence or willful misconduct of the employees or agents of the Company;
- C. providing at no charge, as specified from time to time by the Company, any needed personnel, equipment space and power to operate Company facilities and equipment installed on the premises of the Customer, and the level of heating and air conditioning necessary to maintain the proper operating environment on such premises;
- D. obtaining, maintaining, and otherwise having full responsibility for all rights-of-way and conduits necessary for installation of fiber optic cable and associated equipment used to provide Communication Services to the Customer from the cable building entrance or property line to the location of the equipment space described in 2.3.1(C.). Any and all costs associated with obtaining and maintaining the rights-of-way described herein, including the costs of altering the structure to permit installation of the Company-provided facilities, shall be borne entirely by, or may be charged by the Company to, the Customer. The Company may require the Customer to demonstrate its compliance with this section prior to accepting an order for service;

Issued: August 12, 2014

Effective: September 1, 2014

Issued By:

Sean Dandley, CEO/President
303 Wyman Street Suite 350
Waltham, MA, 02451

SECTION 2 – RULES AND REGULATIONS (CONT'D)**Obligations of the Customer (Cont'd)****General (Cont'd)**

- E. providing a safe place to work and complying with all laws and regulations regarding the working conditions on the premises at which Company employees and agents shall be installing or maintaining the Company's facilities and equipment. The Customer may be required to install and maintain Company facilities and equipment within a hazardous area if, in the Company's opinion, injury or damage to the Company's employees or property might result from installation or maintenance by the Company. The Customer shall be responsible for identifying, monitoring, removing and disposing of any hazardous material (e.g., asbestos) prior to any construction or installation work;
- F. complying with all laws and regulations applicable to, and obtaining all consents, approvals, licenses and permits as may be required with respect to, the location of Company facilities and equipment in any Customer premises or the rights-of-way for which Customer is responsible under Section 2.3.1(D); and granting or obtaining permission for Company agents or employees to enter the premises of the Customer at any time for the purpose of installing, inspecting, maintaining, repairing, or upon termination of service as stated herein removing the facilities or equipment of the Company;
- G. not creating, or allowing to be placed, any liens or other encumbrances on the Company's equipment or facilities; and
- H. making Company facilities and equipment available periodically for maintenance purposes at a time agreeable to both the Company and the Customer. No allowance will be made for the period during which service is interrupted for such purposes.

Issued: August 12, 2014

Effective: September 1, 2014

Issued By:

Sean Dandley, CEO/President
303 Wyman Street Suite 350
Waltham, MA, 02451

SECTION 2 – RULES AND REGULATIONS (CONT'D)**Obligations of the Customer (Cont'd)****Liability of the Customer**

- A. The Customer will be liable for damages to the facilities of the Company and for all incidental and consequential damages caused by the negligent or intentional acts or omissions of the Customer, its officers, employees, agents, invites, or contractors where such acts or omissions are not the direct result of the Company's negligence or intentional misconduct.
- B. To the extent caused by any negligent or intentional act of the Customer as described in A., preceding, the Customer shall indemnify, defend and hold harmless the Company from and against all claims, actions, damages, liabilities, costs and expenses, including reasonable attorneys' fees, for (1) any loss, destruction or damage to property of any third party, and (2) any liability incurred by the Company to any third party pursuant to this or any other rate sheet of the Company, or otherwise, for any interruption of, interference to, or other defect in any service provided by the Company to such third party.
- C. The Customer shall not assert any claim against any other Customer or user of the Company's services for damages resulting in whole or in part from or arising in connection with the furnishing of service under this rate sheet including, but not limited to, mistakes, omissions, interruptions, delays, errors or other defects or misrepresentations, whether or not such other Customer or user contributed in any way to the occurrence of the damages, unless such damages were caused solely by the negligent or intentional act or omission of the other Customer or user and not by any act or omission of the Company. Nothing in this rate sheet is intended either to limit or to expand Customer's right to assert any claims against third parties for damages of any nature other than those described in the preceding sentence.

Issued: August 12, 2014

Effective: September 1, 2014

Issued By:

Sean Dandley, CEO/President
303 Wyman Street Suite 350
Waltham, MA, 02451

SECTION 2 – RULES AND REGULATIONS (CONT'D)**Customer Equipment and Channels****General**

A User may transmit or receive information or signals via the facilities of the Company. The Company's services are designed primarily for the transmission of voice-grade telephonic signals, except as otherwise stated in this tariff. A User may transmit any form of signal that is compatible with the Company's equipment, but the Company does not guarantee that its services will be suitable for purposes other than voice-grade telephonic communication except as specifically stated in this tariff.

Station Equipment

- A. Terminal equipment on the User's Premises and the electric power consumed by such equipment shall be provided by and maintained at the expense of the User. The User is responsible for the provision of wiring or cable to connect its terminal equipment to the Company Point of Connection.
- B. The Customer is responsible for ensuring that Customer-provided equipment connected to Company equipment and facilities is compatible with such equipment and facilities. The magnitude and character of the voltages and currents impressed on Company-provided equipment and wiring by the connection, operation, or maintenance of such equipment and wiring shall be such as not to cause damage to the Company-provided equipment and wiring or injury to the Company's employees or to other persons. Any additional protective equipment required to prevent such damage or injury shall be provided by the Company at the Customer's expense, subject to prior Customer approval of the equipment expense.

Issued: August 12, 2014

Effective: September 1, 2014

Issued By:

Sean Dandley, CEO/President
303 Wyman Street Suite 350
Waltham, MA, 02451

SECTION 2 – RULES AND REGULATIONS (CONT'D)**Customer Equipment and Channels (Cont'd)****Interconnection of Facilities**

- A. Any special interface equipment necessary to achieve compatibility between the facilities and equipment of the Company used for furnishing Communication Services and the channels, facilities, or equipment of others shall be provided at the Customer's expense.
- B. Communications Services may be connected to the services or facilities of other communications carriers only when authorized by, and in accordance with, the terms and conditions of the tariffs of the other communications carriers that are applicable to such connections.
- C. Facilities furnished under this tariff may be connected to Customer-provided terminal equipment in accordance with the provisions of this tariff. All such terminal equipment shall be registered by the Federal Communications Commission pursuant to Part 68 of Title 47, Code of Federal Regulations; and all User-provided wiring shall be installed and maintained in compliance with those regulations.
- D. Users may interconnect communications facilities that are used in whole or in part for interstate communications to services provided under this tariff only to the extent that the user is an "End User" as defined in Section 69.2(m), Title 47, Code of Federal Regulations (1992 edition).

Issued: August 12, 2014

Effective: September 1, 2014

Issued By:

Sean Dandley, CEO/President
303 Wyman Street Suite 350
Waltham, MA, 02451

SECTION 2 – RULES AND REGULATIONS (CONT'D)**Customer Equipment and Channels (Cont'd)****Inspections**

- A. Upon suitable notification to the Customer, and at a reasonable time, the Company may make such tests and inspections as may be necessary to determine that the Customer is complying with the requirements set forth in Section 2.4.2A. for the installation, operation, and maintenance of Customer-provided facilities, equipment, and wiring in the connection of Customer-provided facilities and equipment to Company-owned facilities and equipment.
- B. If the protective requirements for Customer-provided equipment are not being complied with, the Company may take such action as it deems necessary to protect its facilities, equipment, and personnel. The Company will notify the Customer promptly if there is any need for further corrective action. Within ten days of receiving this notice, the Customer must take this corrective action and notify the Company of the action taken. If the Customer fails to do this, the Company may take whatever additional action is deemed necessary, including the suspension of service, to protect its facilities, equipment and personnel from harm.

Issued: August 12, 2014

Effective: September 1, 2014

Issued By:

Sean Dandley, CEO/President
303 Wyman Street Suite 350
Waltham, MA, 02451

SECTION 2 – RULES AND REGULATIONS (CONT'D)**Payment Arrangements****Payment for Service**

The Customer is responsible for the payment of all charges for facilities and services furnished by the Company to the Customer and to all Authorized Users by the Customer, regardless of whether those services are used by the Customer itself or are resold to or shared with other persons.

The Customer is responsible for payment of any sales, use, gross receipts, excise, access or other local, state, federal and 911 taxes, charges or surcharges (however designated) (excluding taxes on Company's net income) imposed on or based upon the provision, sale or use of Network Services.

The security of the Customer's PIN is the responsibility of the Customer. All calls placed using a PIN shall be billed to and shall be the obligation of the Customer. The Customer shall not be responsible for charges in connection with the unauthorized use of PINs arising after the Customer notifies the Company of the loss, theft, or other breach of security of such PINs.

Customers will only be charged once, on either an interstate or intrastate basis, for any nonrecurring charges.

Billing and Collection of Charges

The Customer is responsible for payment of all charges incurred by the Customer or other Authorized Users for services and facilities furnished to the Customer by the Company.

- A. Nonrecurring charges are due and payable within thirty (30) days of receipt of bill, unless otherwise agreed to in advance.
- B. The Company shall present invoices for recurring charges monthly to the Customer, in advance of the month in which service is provided, and Recurring Charges shall be due and payable within thirty (30) days of receipt of bill. When billing is based on customer usage, charges will be billed monthly for the preceding billing periods.

Issued: August 12, 2014

Effective: September 1, 2014

Issued By:

Sean Dandley, CEO/President
303 Wyman Street Suite 350
Waltham, MA, 02451

SECTION 2 – RULES AND REGULATIONS (CONT'D)**Payment Arrangements (Cont'd)****Billing and Collection of Charges (Cont'd)**

- C. When service does not begin on the first day of the month, or end on the last day of the month, the charge for the fraction of the month in which service was furnished will be calculated on a pro rata basis. For this purpose, every month is considered to have thirty (30) days.
- D. Billing of the Customer by the Company will begin on the Service Commencement Date, which is the first day following the date on which the Company notifies the Customer that the service or facility is available for use, except that the Service Commencement Date may be postponed by mutual agreement of the parties, or if the service or facility is available for use, except that the Service Commencement Date may be postponed by mutual agreement of the parties, or if the service or facility does not conform to standards set forth in this tariff or the Service Order. Billing accrues through and includes the day that the service, circuit, arrangement or component is discontinued.
- E. If any portion of the payment is not received by the Company, or if any portion of the payment is received by the Company in funds that are not immediately available, thirty (30) days following the receipt date of the bill, then a late payment penalty shall be due the Company. The late payment penalty shall be that portion of the payment not received by the date due minus any charges billed as local taxes multiplied by 1.5%. Late payment fees are only applicable to business customers.
- F. The Customer will be assessed a charge of twenty-five dollars (\$25.00) for each check or other payment type submitted by the Customer to the Company that a financial institution refuses to honor.
- G. If service is disconnected by the Company in accordance with Section 2.5.6 following and later restored, restoration of service will be subject to all applicable installation charges.

Issued: August 12, 2014

Effective: September 1, 2014

Issued By:

Sean Dandley, CEO/President
303 Wyman Street Suite 350
Waltham, MA, 02451

SECTION 2 – RULES AND REGULATIONS (CONT'D)**Payment Arrangements (Cont'd)****Disputed Bills**

- A. In the event that a billing dispute occurs concerning any charges billed to the Customer by the Company, the Company may require the Customer to pay the undisputed portion of the bill to avoid discontinuance of service for non-payment. The Customer must submit a documented claim for the disputed amount. The Customer will submit all documentation as may reasonably be required to support the claim. All claims must be submitted to the Company within 90 days of receipt of billing for those services. If the Customer does not submit a claim as stated above, the Customer waives all rights to filing a claim thereafter.
- B. Unless disputed, the invoice shall be deemed to be correct and payable in full by the Customer. If the Customer is unable to resolve any dispute with the Company, then the Customer may file a complaint with the Texas Division of Public Utility Commission, located at 1701 N. Congress Ave, PO Box 13326, Austin, TX 78711-3326
- C. If the dispute is resolved in favor of the Customer and the Customer has withheld the disputed amount, no interest credits or penalties will apply.

Advance Payments

- A. The Company may require a Customer to make an advance payment before services and facilities are furnished. The advance payment will not exceed an amount equal to the non-recurring charge(s) and one month's charges for the service or facility. In addition, where special construction is involved, the advance payment may also include an amount equal to the estimated non-recurring charges for the special construction and recurring charges (if any) for a period to be set between the Company and the Customer. The advance payment will be credited to the Customer's initial bill. An advance payment may be required in addition to a deposit.

SECTION 2 – RULES AND REGULATIONS (CONT'D)**Payment Arrangements (Cont'd)****Deposits**

A. Residential Customers

The Company does not collect deposits from residential customers.

B. Commercial Customers

1. The Company may, in order to safeguard its interests, require a Customer which has a proven history of late payments to the Company or does not have established credit or has a bad credit rating to make a deposit to or at any time after the provision of service to the Customer to be held by the Company as a guarantee of the payment of rates and charges. No such deposit will be required of a Customer which has established satisfactory credit and has no history of late payments to the Company.
2. The amount of the deposit which may be required of a Customer for the purpose of establishing a credit shall not exceed two times the average monthly bill for residential Customers whose bills are payable in advance. The amount of deposit may be adjusted at the request of the Customer at any time when the character, purpose, or degree of the Customer's use of the service has materially changed, or when it is indicated that it will change.
3. The making of a deposit shall not relieve any Customer of the obligation to pay current bills when due. A deposit shall only be applied to the indebtedness of the Customer for jurisdictional telecommunications services of the provider.

SECTION 2 – RULES AND REGULATIONS (CONT'D)**S****Payment Arrangements (Cont'd)****Deposits (Cont'd)****C. Commercial Customers (Cont'd)**

1. The Company shall keep a record of each cash deposit until the deposit is returned. The record will show the name of each Customer making a deposit; the premises occupied by the Customer when making the deposit and each successive premises occupied while the deposit is retained by the Company; the amount and date of make the deposit; and a record of each transaction, such as the payment of interest, interest credited, etc., concerning the deposit. Concurrently with receiving a deposit, the Company will provide the Customer a receipt showing the deposit date, the name and billing address of the Customer and the deposit amount.
2. Upon discontinuation of service, or when a Customer has established credit by other means, the Company will promptly refund any deposit, plus accrued simple interest, or the balance, if any, in excess of the unpaid bills for the services furnished by the Company. A transfer of service from one location to another within the Company's serving area shall not be deemed a discontinuance with the Company if the character of the service remains unchanged.
3. Deposits will be refunded after twelve months of timely payment.

Issued: August 12, 2014

Effective: September 1, 2014

Issued By:

Sean Dandley, CEO/President
303 Wyman Street Suite 350
Waltham, MA, 02451

SECTION 2 – RULES AND REGULATIONS (CONT'D)**Payment Arrangements (Cont'd)****Discontinuance of Service**

Without incurring liability DSCI may refuse or discontinue service for the following reasons, provided that, unless otherwise stated, business customers will be given five (5) days write notice and residential customers will be given fifteen (15) days written notice by first class mail and a financial notice by Certified Mail (5) days prior to discontinuance.

- A. For noncompliance with or violation of any State, municipal, or Federal law, ordinance or regulation pertaining to telephone service.
- B. For noncompliance with or violation of Commission regulation or DSCI's rules and regulations on file with the Commission.
- C. Without notice by reason of any order or decision of a court or other government authority having jurisdiction which prohibits Company from furnishing such services.
- D. For failure of the Customer to make proper application for service or for use of telephone service for any other property or purpose than that described in the application.

Issued: August 12, 2014

Effective: September 1, 2014

Issued By:

Sean Dandley, CEO/President
303 Wyman Street Suite 350
Waltham, MA, 02451

SECTION 2 – RULES AND REGULATIONS (CONT'D)**Payment Arrangements (Cont'd)****Discontinuance of Service (Cont'd)**

- E. Without notice in the event of tampering with the equipment or services owned by DSCI or its agents.
- F. Without notice in the event of Customer use of equipment or services in such a manner as to adversely affect the Company's equipment or the Company's service to others.
- G. For neglect or refusal to provide reasonable access to DSCI or its agents for the purpose of inspection and maintenance of equipment owned by DSCI or its agents.
- H. For non-payment of any amount past due to the Company by the Customer.
- I. Without notice for unauthorized or unlawful use of Authorization Codes. Authorization Codes are issued only by the Company to the Customer and may not be sold or otherwise distributed without the written consent of the Company.
- J. Without notice in the event of any other unauthorized or fraudulent use of service. Whenever service is discontinued for fraudulent use of service, DSCI may, before restoring service, require the Customer to make, at his or her own expense, all changes in facilities or equipment necessary to eliminate illegal use and to pay an amount reasonable estimated as the loss in revenues resulting from such fraudulent use.
- K. For Customer's breach of contract for service between the Company and the Customer.

Issued: August 12, 2014

Effective: September 1, 2014

Issued By:

Sean Dandley, CEO/President
303 Wyman Street Suite 350
Waltham, MA, 02451

SECTION 2 – RULES AND REGULATIONS (CONT'D)**Payment Arrangements (Cont'd)****Cancellation of Application for Service**

- A. Applications for service cannot be canceled without the Company's agreement. Where the Company permits a Customer to cancel an application for service prior to the start of service or prior to any special construction, no charges will be imposed except for those specified below.
- B. Where, prior to cancellation by the Customer, the Company incurs any expenses in installing the service or in preparing to install the service that it otherwise would not have incurred, a charge equal to the costs incurred by the Company, less net salvage, shall apply, but in no case shall this charge exceed the sum of the charge for the minimum period of services ordered, including installation charges, and all charges others levy against the Company that would have been chargeable to the Customer had service commenced.
- C. Where the Company incurs any expense in connection with special construction, or where special arrangements of facilities or equipment have begun, before the Company receives a cancellation notice, a charge equal to the costs incurred by the Company, less net salvage, applies. In such cases, the charge will be based on such elements as the cost of the equipment, facilities, and material, the cost of installation, engineering, labor, and supervision, general and administrative expense, other disbursements, depreciation, maintenance, taxes, provision for return on investment, and any other costs associated with the special construction or arrangements.
- D. The special charges described in 2.5.7(A) through 2.5.7(C) will be calculated and applied on a case-by-case basis.

Changes in Service Requested

If the Customer makes or request material changes in circuit engineering, equipment specifications, service parameters, premises locations, or otherwise materially modifies any provision of the application for service, the Customer's installation fee shall be adjusted accordingly.

Issued: August 12, 2014

Effective: September 1, 2014

Issued By:

Sean Dandley, CEO/President
303 Wyman Street Suite 350
Waltham, MA, 02451

SECTION 2 – RULES AND REGULATIONS (CONT'D)**Allowances for Interruptions in Service**

Interruptions in service that are not due to the negligence of, or noncompliance with the provisions of this tariff by, the Customer or the operation or malfunction of the facilities, power or equipment provided by the Customer, will be credited to the Customer as set forth in 2.6.1 for the part of the service that the interruption affects.

General

- A. A credit allowance will be given when service is interrupted, except as specified below. A service is interrupted when it becomes inoperative to the Customer, e.g., the Customer is unable to transmit or receive, because of a failure of a component furnished by the Company under this rate sheet.
- B. An interruption period begins when the Customer reports a service, facility or circuit to be inoperative and, if necessary, releases it for testing and repair. An interruption period ends when the service, facility or circuit is operative.
- C. If the Customer reports a service, facility or circuit to be interrupted but declines to release it for testing and repair, or refuses access to its premises for test and repair by the Company, the service, facility or circuit is considered to be impaired but not interrupted. No credit allowances will be made for a service, facility or circuit considered by the Company to be impaired.
- D. The Customer shall be responsible for the payment of service charges as set forth herein for visits by the Company's agents or employees to the premises of the Customer when the service difficulty or trouble report results from the use of equipment or facilities provided by any party other than the Company, including but not limited to the Customer.

Issued: August 12, 2014

Effective: September 1, 2014

Issued By:

Sean Dandley, CEO/President
303 Wyman Street Suite 350
Waltham, MA, 02451

SECTION 2 – RULES AND REGULATIONS (CONT'D)**Allowances for Interruptions in Service (Cont'd)****Limitations of Allowances**

No credit allowance will be made for any interruption in service:

- A. Due to the negligence of or noncompliance with the provisions of this rate sheet by any person or entity other than the Company, including, but not limited to, the Customer;
- B. Due to the failure of power, equipment, systems, connections or services not provided by the Company;
- C. Due to circumstances or causes beyond the reasonable control of the Company;
- D. During any period in which the Company is not given full and free access to its facilities and equipment for the purposes of investigating and correcting interruptions;
- E. A service will not be deemed to be interrupted if a Customer continues to voluntarily make use of such service. If the service is interrupted, the Customer can get a service credit, use another means of communications provided by the Company (pursuant to Section 2.6.3), or utilize another service provider;
- F. During any period when the Customer has released service to the Company for maintenance purposes or for implementation of a Customer order for a change in service arrangements;
- G. That occurs or continues due to the Customer's failure to authorize replacement of any element of special construction; and
- H. That was not reported to the Company within thirty (30) days of the date that service was affected.

Issued: August 12, 2014

Effective: September 1, 2014

Issued By:

Sean Dandley, CEO/President
303 Wyman Street Suite 350
Waltham, MA, 02451

SECTION 2 – RULES AND REGULATIONS (CONT'D)**Allowances for Interruptions in Service (Cont'd)****Use of Another Means of Communication**

If the Customer elects to use another means of communications during the period of interruption, the Customer must pay the charges for the alternative service used.

Application for Credits for Interruptions in Service

- A. Credits for interruptions in service that is provided and billed on a flat rate basis for a minimum period of at least one month, beginning on the date that billing becomes effective, shall in no event exceed an amount equivalent to the proportionate charge to the Customer for the period of service during which the event that gave rise to the claim for a credit occurred. A credit allowance is applied on a pro rata basis against the rates specified hereunder and is dependent upon the length of the interruption. Only those facilities on the interrupted portion of the circuit will receive a credit.
- B. For calculating credit allowances, every month is considered to have thirty (30) days.
- C. A credit allowance will be given for interruptions of thirty (30) minutes or more. Two or more interruptions of fifteen (15) minutes or more during any one 24-hour period shall be combined into one cumulative interruption.
- D. Interruptions of 24 Hours or Less

Length of Interruption	Amount of Service to be Credited
Less than 30 minutes	None
30 minutes up to but not including 3	1/10 Day
3 hours up to but not including 6 hours	1/5 Day
6 hours up to but not including 9 hours	2/5 Day
9 hours up to but not including 12	3/5 Day
12 hours up to but not including 15	4/5 Day
15 hours up to but not including 24	One Day

Issued: August 12, 2014

Effective: September 1, 2014

Issued By:

Sean Dandley, CEO/President
303 Wyman Street Suite 350
Waltham, MA, 02451

SECTION 2 – RULES AND REGULATIONS (CONT'D)**Allowances for Interruptions in Service (Cont'd)****E. Interruptions Over 24 Hours and Less Than 72 Hours**

Interruptions over 24 hours and less than 72 hours will be credit 1/5 day for each 3-hour period or fraction thereof. No more than one full day's credit will be allowed for any period of 24 hours.

F. Interruptions over 72 hours will be credited 2 days for each full 24-hour period. No more than thirty (30) days credit will be allowed for any one-month period.**Cancellation for Service Interruption**

Cancellation or termination for service interruption is permitted only if any circuit experiences a single continuous outage of 8 hours or more or cumulative service credits equaling 16 hours in a continuance 12- month period. The right to cancel service under this provision applies only to the single circuit that has been subject to the outage or cumulative service credits.

Use of Customer's Service by Others**Joint Use Arrangements**

Joint use arrangements will be permitted for all services provided under this tariff. From each joint use arrangement, one member will be designated as the Customer responsible for the manner in which the joint use of the service will be allocated. The Company will accept orders to start, rearrange, relocate or discontinue service only from the designated Customer. Without affecting the Customer's ultimate responsibility for payment of all charges for the service, each joint user shall be responsible for the payment of the charges billed to Customers

Issued: August 12, 2014

Effective: September 1, 2014

Issued By:

Sean Dandley, CEO/President
303 Wyman Street Suite 350
Waltham, MA, 02451

SECTION 2 – RULES AND REGULATIONS (CONT'D)**Cancellation of Service/Termination Liability**

If a Customer cancels a Service Order or terminates services before the completion of the term for any reason whatsoever other than a service interruption (as defined in Section 2.6.1 above), the Customer agrees to pay to the Company termination liability charges, as defined below. These charges shall become due as of the effective date of the cancellation or termination and be payable within the period, set forth in Section 2.5.2.

Termination Liability

The Customer's termination liability for cancellation of service shall be equal to:

- A. all unpaid Non-Recurring charges reasonably expended by the Company to establish service to the Customer; plus
- B. any disconnection, early cancellation or termination charges reasonable incurred and paid to third parties by the Company on behalf of the Customer; plus
- C. all Recurring Charges specified in the applicable Service Order Tariff for the balance of the then current term discounted at the prime rate announced in the Wall Street Journal on the third business day following the date of cancellation;
- D. minus a reasonable allowance for costs avoided by the Company as a direct result of the Customer's cancellation.

Transfers and Assignments

Neither the Company nor the Customer may assign or transfer its rights or duties in connection with the services and facilities provided by the Company without the written consent of the other party, except that the Company may assign its rights and duties:

- 1: to any subsidiary, parent company or affiliate of the Company; or
- 2: pursuant to any sale or transfer of substantially all the assets of the Company; or
- 3: pursuant to any financing, merger or reorganization of the Company.

Issued: August 12, 2014

Effective: September 1, 2014

Issued By:

Sean Dandley, CEO/President
303 Wyman Street Suite 350
Waltham, MA, 02451

SECTION 2 – RULES AND REGULATIONS (CONT'D)**Customer Liability for Unauthorized Use of the Network**

Unauthorized use of the network occurs when a person or entity that does not have actual, apparent or implied authority to use the network, obtains the Company's services provided under this rate sheet.

Customer Liability for Fraud and Unauthorized Use of the Network

- A. The Customer is liable for the unauthorized use of the network obtained through the fraudulent use of a Company calling card, if such a card is offered by the Company, or an accepted credit card, provided that the unauthorized use occurs before the Company has been notified.
- B. A Company calling card is a telephone calling card issued by the Company at the Customer's request, which enables the Customer or user(s) authorized by the Customer to place calls over the Network and to have the charges for such calls billed to the Customer's account.

An accepted credit card is any credit card that a cardholder has requested or applied to and received, or has signed, used, or authorized another person to use to obtain credit. Any credit card issued as a renewal or substitute in accordance with this paragraph is an accepted credit card when received by the cardholder.

- C. The Customer must give the Company written or oral notice that an unauthorized use of a Company calling card or an accepted credit card has occurred or may occur as a result of loss and/or theft.
- D. The Customer is responsible for payment of all charges for calling card services furnished to the Customer or to users authorized by the Customer to use service provided under this rate sheet, unless due to the negligence of the Company. This responsibility is not changed due to any use, misuse or abuse of the Customer's service or Customer-provided equipment by third parties, the Customer's employees, or the public.

The liability of the Customer for unauthorized use of the Network by credit card fraud will not exceed the lesser of fifty dollars (\$50.00) or the amount of money, property, labor, or services obtained by the unauthorized user before notification to the Company.

Issued: August 12, 2014

Effective: September 1, 2014

Issued By:

Sean Dandley, CEO/President
303 Wyman Street Suite 350
Waltham, MA, 02451

SECTION 2 – RULES AND REGULATIONS (CONT'D)**Notices and Communications**

The Customer shall designate on the Service Order an address to which the Company shall mail or deliver all notices and other communications, except that the Customer may also designate a separate address to which the Company's bills for service shall be mailed.

The Company shall designate on the Service Order an address to which the Customer shall mail or deliver all notices and other communications, except that Company may designate a separate address on each bill for service to which the Customer shall mail payment on that bill.

Except as otherwise stated in this tariff, all notices or other communications required to be given pursuant to this tariff will be in writing. Notices and other communications of either party, and all bills mailed by the Company, shall be presumed to have been delivered to the other party on the third business day following placement of the notice, communication or bill with the U.S. Mail or a private delivery service, prepaid and properly addressed, or when actually received or refused by the addressee, whichever occurs first.

The Company or the Customer shall advise the other party of any changes to the addresses designated for notices, other communications or billing, by following the procedures for giving notice set forth herein.

Taxes, Fees and Surcharges

The Company reserves the right to bill any and all applicable taxes, fees and surcharges in addition to the normal rates and charges for services provided to the Customer. Taxes and fees include, but are not limited to: Federal Excise Tax, State Sales Tax, Municipal Tax, and Gross Receipts Tax. Unless otherwise specified in this tariff, such taxes, fees and surcharges are in addition to rates as quoted in this tariff and will be itemized separately on Customer invoices.

Issued: August 12, 2014

Effective: September 1, 2014

Issued By:

Sean Dandley, CEO/President
303 Wyman Street Suite 350
Waltham, MA, 02451

SECTION 2 – RULES AND REGULATIONS (CONT'D)**Miscellaneous Provisions****Telephone Number Changes**

Whenever any Customer's telephone number is changed after a directory is published, the Company shall intercept all calls to the former number for at least one hundred and twenty (120) days and give the calling party the new number provided existing central office equipment will permit, and the Customer so desires.

When service in an existing location is continued for a new Customer, the existing telephone number may be retained by the new Customer only if the former Customer consents in writing, and if all charges against the account are paid or assumed by the new Customer.

Maintenance and Operations Records

Records of various tests and inspections, to include non-routine corrective maintenance actions or monthly traffic analysis summaries for network administration, necessary for the purposes of the Company or to fulfill the requirements of the Commission rules shall be kept on file in the office of the Company as required under Commission rule

Issued: August 12, 2014

Effective: September 1, 2014

Issued By:

Sean Dandley, CEO/President
303 Wyman Street Suite 350
Waltham, MA, 02451

SECTION 3 - DESCRIPTION OF SERVICE AND RATES

Service Offerings

Switched Long Distance Service

Switched Long Distance Service is a usage based direct dialed interexchange service, which utilizes switched access facilities from equal access locations, on the originating end of each call. Calls are billed in a maximum of 60 second increments. All charges are billed monthly in arrears.

Switched Toll-Free Service

Switched Toll-Free Service provides Toll-Free calls to terminating points throughout the state of Pennsylvania, which utilizes switched access facilities from equal access locations, on the terminating end of each call. Charges for the Toll-Free calls are billed to the Company's customers rather than the caller. Calls are billed in a maximum of 60 second increments with initial call duration of 60 seconds. All charges are billed monthly in arrears.

Dedicated Long Distance Service

Dedicated Long Distance Service is a direct dialed interexchange service, which utilizes dedicated access facilities on the originating end of each call. Calls are billed in 6 second increments with initial call duration of 6 seconds. All charges are billed monthly in arrears.

Dedicated Toll Free Service

Dedicated Toll Free Service provides inbound '800/888/877/866' calling to points terminating within the State of Pennsylvania utilizing dedicated access facilities on the terminating end of each call. Charges for the '800/888/877/866' calls are billed to the Company's Customers rather than to the originating caller. Calls are billed in 6 second increments with initial call duration of 18 seconds. All charges are billed monthly in arrears.

iPBX SIP Trunking

PBX SIP Trunking sends the voice traffic from your current phone system over the same Internet connection you're already using for data, eliminating the need for a separate voice connection. This service provides VoIP features such as bundled usage, extension dialing between sites, and support for remote users. iPBX SIP Trunking also supports legacy interfaces on your phone system (such as PRI, CAS T1, or analog), helping you to avoid costly upgrades.

Metro Ethernet

Metro Ethernet is used to connect subscribers to a larger service network or the Internet. Businesses can also use metropolitan-area Ethernet to connect their own offices to each other. DSCI Provides bandwidth in excess of 10 Mbps³

Issued: August 12, 2014

Effective: September 1, 2014

Issued By:

Sean Dandley, CEO/President
303 Wyman Street Suite 350
Waltham, MA, 02451

SECTION 3 - DESCRIPTION OF SERVICE AND RATES (CONT'D)

Service Offerings (Cont)

MPLS VPN Service

MPLS VPN lets you combine the data, Internet, voice, video, and Unified Communications traffic from multiple sites onto a single network

Hosted Secure Internet Gateway Service

Allows customers to safely connect to the public internet through a managed firewall solution.

Dedicated Internet Access:

Allows customers to choose a range of dedicated bandwidth options, without using their local internet provider.

UCx (Hosted Unified Communications Service)

UCx unites voice, video, messaging, and collaboration tools into one powerful cloud-based service. With desktop and mobile applications, customers have access to their communications from anywhere, on any device, at any time you choose.

Issued: August 12, 2014

Effective: September 1, 2014

Issued By:

Sean Dandley, CEO/President
303 Wyman Street Suite 350
Waltham, MA, 02451

SECTION 3 - DESCRIPTION OF SERVICE AND RATES (CONT'D)**Basic Toll Free Service****General**

Basic Toll Free service provides for dial-type communications between a toll free access line (e.g. 800/888) and exchanges by this Company and by participating companies within the LATA in Pennsylvania. Dial-type communications is a dialed call received by the Customer over a toll free service access line, or if its facilities are not available for dial completion from a station, a call placed with an operator by giving the calling telephone number and the Customer's toll free service access line number.

Basic Toll Free Service permits calling in one direction only, via an access line, from all exchanges within a LATA. A toll free service access line, connecting the Customer's premises and a Company central office, is provided for receiving toll free service calls. Toll free service access lines provided on the same premises of a Customer are arranged as service groups. A service group consists of one line or two or more lines in a multi-line sequence arranged for line hunting.

Basic Toll Free Service may be furnished on the same premises of a Customer with either measured or unlimited main telephone exchange service.

Limitations

1. Toll Free Service does not include person to person, collect, conference, or other calls requiring operator handling.
2. Service may be furnished only when and for so long as the Customer subscribes to a sufficient number of access lines to adequately handle the volume of telephone calls received, without interfering with any of the services offered by the Company.

Temporary Suspension of Service

Toll Free Service is not subject to a temporary suspension of service arrangement.

Service Interruption

Credit is given for interruption to an access line of 24 consecutive hours or more. An interruption to an access line not due to the negligence of the Customer is credited at one-thirteenth of the monthly charge for the access line for each 24 hours or any fraction thereof of interruption.

MTS furnished at the calling party's request, if Toll Free service is interrupted, is charged for at MTS rates.

Issued: August 12, 2014

Effective: September 1, 2014

Issued By:

Sean Dandley, CEO/President
303 Wyman Street Suite 350
Waltham, MA, 02451

SECTION 3 - DESCRIPTION OF SERVICE AND RATES (CONT'D)**Directory Assistance**

Initial and Additional Directory Listings may be provided with Basic Toll Free Service in accordance with the terms of this Tariff.

Application of Rates and Charges

3. Timing of Calls - Except as otherwise specified herein, timing begins when connection is established between a telephone associated with a toll free service access line and the calling telephone and ends when the calling telephone hangs up, thereby releasing the network connection. If the called telephone hangs up, but the calling telephone does not, timing ends when the network connection is released by automatic timing equipment in the telecommunications network.
4. Channels for Additional Termination of Access Lines - For additional terminations between points in the same exchange but not on the same premises, or additional terminations between points different exchanges within a LATA, rates and charges apply for a Private line Type 2001A intraexchange/interexchange channel.
- 5.
6. Service charges apply in addition to the Toll Free service dial tone line and usage charges.

Determination of Usage Charges

IntraLATA usage charges are determined in accordance with the following steps:

7. Determine the total number of calls for each access line billed to the same account.
8. Determine the total actual seconds used for the access line(s) in a service group; divide by 60; and if the number of minutes results in a fractional part of a minute, round to the next higher minute.
9. The applicable charges equal the number of calls determined, multiplied by the per message charges for Toll Free Service, plus the number of minutes determined multiplied by the per minute charge for Toll Free Service.

Issued: August 12, 2014

Effective: September 1, 2014

Issued By:

Sean Dandley, CEO/President
303 Wyman Street Suite 350
Waltham, MA, 02451

SECTION 3 - DESCRIPTION OF SERVICE AND RATES (CONT'D)

Local Exchange Service:

General

The Company offers Local Service to business customers. Voice Mail and other Custom Calling Features are available to Local Service customers by selecting such services a la carte or in bundled packages.

Local Dial tone Service

General

The Company offers local dial tone service to customers in all available Texas Exchange Areas. Local dial tone service allows customers to initiate and terminate calls within their local calling areas.

Local Service Packages

General

Bundled packages provides customers with local dial tone service and can include one or all of the following Calling features.

Issued: August 12, 2014

Effective: September 1, 2014

Issued By:

Sean Dandley, CEO/President
303 Wyman Street Suite 350
Waltham, MA, 02451

SECTION 3 - DESCRIPTION OF SERVICE AND RATES (CONT'D)

Local Service Packages (cont'd)

Standard Features

Anonymous Call Rejection	Reject calls from callers who have restricted caller ID.
Anywhere	Extend desk phone features to any fixed or mobile device. Move calls between devices without hanging up.
Automatic Callback	Automatically call back a busy party when they become available.
Basic Call Logs	View and dial from a list of recent communications.
Call Center - Premium	Inbound and outbound call center allowing up to 525 queued calls.
Call Forwarding	Define criteria that cause certain incoming calls to be automatically redirected to another destination.
Call Notify	Define multiple criteria sets that cause certain incoming calls to trigger an e-mail notification or text message.
Call Return	Calls the last party you called, whether or not the call was answered.
Call Transfer	Transfer a call to another phone.
Call Waiting	Answer a call while already on another call.
Calling Line ID Blocking Override	Receive caller ID regardless of whether or not it is blocked by the calling party.
Calling Line ID Delivery Blocking	Block delivery of your caller ID to the called party.
Calling Name Retrieval	Enables caller ID with name.
Call Return	Call the last party that called, whether or not the call was answered.
Charge Number	Enables administrators to specify an automatically assigned charge number to select users.
Click-to-Dial	Use to initiate voice calls through the desk phone.
Client Call Control	Enable call control features
Corporate Directory	Use to browse and dial from a list of all users in the enterprise.

Issued: August 12, 2014

Effective: September 1, 2014

Issued By:

Sean Dandley, CEO/President
303 Wyman Street Suite 350
Waltham, MA, 02451

Customer Originated Call Trace	Issue a trace for your last incoming call by using a feature access code.
Desktop Sharing	instantly start a desktop sharing session that anyone you invite can join
Directed Call Pickup	Answer a call to another phone in the group.
Diversion Inhibitor	Prevent redirected calls from being redirected again.
Do Not Disturb	Automatically forward your calls to voicemail.
Executive/Assistant	Monitor status (available or busy) of other lines. Generally used by a receptionist or assistant to screen calls.
Extension Dialing	Dial a short number to call another user within the enterprise.
External/Internal Calling Line ID Delivery	Enable delivery of caller ID (phone number and name).
File Transfer	instantly transmit a file from your computer to another user.
Flash Call Hold	Hold a call with a feature access code when using a simple phone without call control capability.
Hoteling Guest	Log in to a shared "host" phone on an as-needed basis.
Hoteling Host	Hoteling Guest users can log in to your desk phone on an as-needed basis.
Instant Messaging	Chat with any other user in the enterprise.
Last Number Redial	Call the last number that you dialed.
Meet-Me Conferencing	Initiate scheduled and reservation less audio conferences.
N-Way Calling	Add up to 12 parties to a call.
Outlook Integration	Integrate personal contacts in Microsoft Outlook.
Presence	Use this feature to see if a contact is available and willing to communicate with you.
Privacy Service	Allows users to exclude themselves from the group and directory listing visible to other users.
Push to Talk	User-to-user intercom service.
Remote Office	Use any other phone as your business phone.

Issued: August 12, 2014

Effective: September 1, 2014

Issued By:

Sean Dandley, CEO/President
303 Wyman Street Suite 350
Waltham, MA, 02451

Sequential Ring	Define a "find me" list of phone numbers that are alerted sequentially for incoming calls.
Simultaneous Ring	Inbound calls ring multiple phones simultaneously.
Speed Dial 8	Dial a pre-defined number by dialing only one digit.
Speed Dial 100	Dial a pre-defined number by dialing a Speed Dial 100 prefix and two digits.
Three-Way Calling	Start a conference call with two other people.
Unified Messaging	Voicemail can be delivered, by email (text or WAV file), or in a voice portal accessible from any phone.
Video Calling	Place and receive video calls or with a video-enabled desk phone with built-in camera).
Web Portal	Use a web portal to activate and customize services.

Optional Features

Enterprise Toolbar	Place/accept calls and change call settings from Microsoft Outlook, Internet Explorer, or Firefox.
--------------------	----------------------------------------------------------------------------------------------------

Available Add-Ons

Call Center Agent Client	A web-based application allowing a call center agent to join the call center, view call and queue info, set ACD state, and more.
Call Center Supervisor Client	A web-based application providing advanced queue control and reporting capabilities for call center supervisors.
Fax Messaging	Receive, store, review, and manage fax messages. Users are notified of new fax messages similarly to voice messages.
Receptionist Client	A web-based application providing a full set of call control options, including call transfer, line monitoring, queuing, conferencing, and corporate directory access.

Issued: August 12, 2014

Effective: September 1, 2014

Issued By:

Sean Dandley, CEO/President
303 Wyman Street Suite 350
Waltham, MA, 02451

SECTION 3 - DESCRIPTION OF SERVICE AND RATES (CONT'D)

Local Service Packages (cont'd)

Rates:

Rates are determined by product types and enabled features and are Monthly recurring charges.

Issued: August 12, 2014

Effective: September 1, 2014

Issued By:

Sean Dandley, CEO/President
303 Wyman Street Suite 350
Waltham, MA, 02451

SECTION 3 - DESCRIPTION OF SERVICE AND RATES (CONT'D)

Switched Services

General

The Company will provide originating and terminating long distance telecommunication services throughout the state of Texas via Feature Group D Access obtained from applicable LECs.

Provision and Description

The Company provides Feature Group D originating and terminating Switched Access. The service categories are differentiated by their technical characteristics and the manner in which an end user accesses them when originating calls. Terminating Calling permits the delivery of calls from the customer's premises to telephone exchange service locations. Originating Calling permits the delivery of calls from telephone exchange service locations to the customer's premises. Two-way Calling permits the delivery of calls in both directions, but not simultaneously.

Feature Group D

FG D Access, which is available to all customers, provides trunk side access to Company End Office switches with an associated uniform 10XXX access code for the Customer's use in originating and terminating communications. No access code is required for calls to a customer over FG D if the end user's telephone exchange service is arranged for pre-subscription to that customer.

8XX Toll-Free

8XX Toll-Free is a service offering utilizing originating trunk side Switched. The service provides for the forwarding of end user dialed 8XX calls to a Company Service Switching Point which will initiate a query to the data base to perform the Customer identification and delivery function. The call is forwarded to the appropriate customer based on the dialed 8XX number.

Issued: August 12, 2014

Effective: September 1, 2014

Issued By:

Sean Dandley, CEO/President
303 Wyman Street Suite 350
Waltham, MA, 02451

SECTION 3 - DESCRIPTION OF SERVICE AND RATES (CONT'D)

Switched Services (Cont'd)

Traffic Types

The major traffic types are originating, terminating and directory assistance. When ordering capacity for, FGD access, the customer must at a minimum specify such access capacity in terms of originating traffic type and/or terminating traffic type. Originating Traffic represents access capacity within a LATA for carrying traffic from the end user to the customer. Because some customers may want to further segregate their originating FGD traffic into separate trunk groups or because segregation may be required by technical limitations. When ordering the following originating traffic types of access capacity, the FGD customer must specify the specific traffic type being ordered.

1. Domestic. Domestic traffic type represents access capacity for carrying only domestic traffic other than 800, 900 and operator traffic.
2. 800
3. 900
4. Operator 800, 900 and operator traffic types represent access capacity for carrying respectively only 800, 900 or operator traffic.

Terminating Traffic represents access capacity within a LATA for carrying traffic from the customer to the end user.

Directory Assistance Traffic represents access capacity within a LATA for carrying directory assistance traffic from the customer to a directory assistance location. Directory assistance traffic type is used for ordering directory assistance

Switched Access Rate Categories

There are four rate categories that apply to Switched Services:

Carrier Common Line

Common Transport (includes Transport Facility, Transport Mileage, and Interconnection Charge)

End Office/Local Switching

8XX Toll-Free

Issued: August 12, 2014

Effective: September 1, 2014

Issued By:

Sean Dandley, CEO/President
303 Wyman Street Suite 350
Waltham, MA, 02451

SECTION 3 - DESCRIPTION OF SERVICE AND RATES (CONT'D)

Switched Services (Cont'd)

The following diagram depicts a generic view of the components of Switched Access Services.

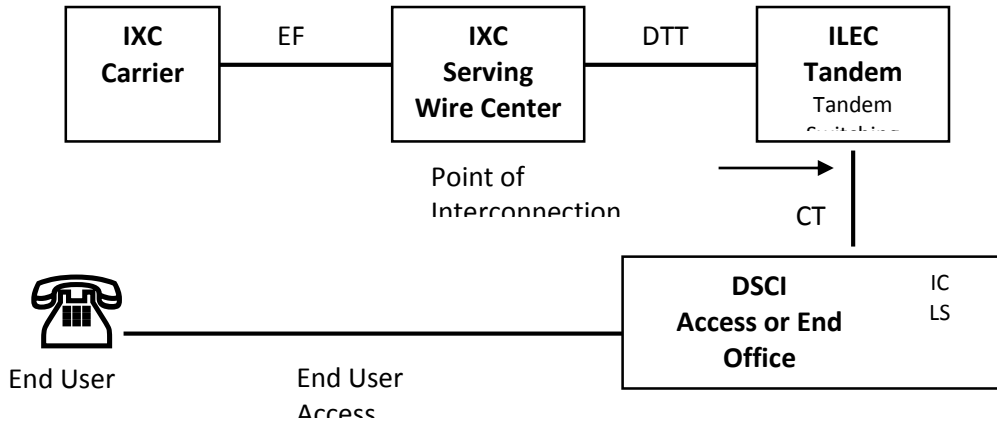

ILEC bills:

EF - Entrance Facility
DTT - Direct Trunk Transport (if to ILEC tandem)
Tandem Switching

DSCI bills:

CT - Common Transport
IC - Interconnection Charge
LS - End Office/Local Switching
CCL - Carrier Common Line

SECTION 4 - MISCELLANEOUS

Issued: August 12, 2014

Effective: September 1, 2014

Issued By:

Sean Dandley, CEO/President
303 Wyman Street Suite 350
Waltham, MA, 02451

General

Each Customer is charged individually for each call placed through the Company. Charges may vary by service offering, class of call, time of day, day of week, class of call and/or call duration.

Late Payment Charge

The company will charge a one-time 1.50% late payment fee on all invoices not paid by the due date identified on the Company bill.

Return Check Charge

The Company will assess a return check charge of up to \$25.00 whenever a check or draft presented for payment of service is not accepted by the institution on which it is written. This charge applies each time a check is returned to the Company by a bank for insufficient funds.

SECTION 5 - RATES

Issued: August 12, 2014

Effective: September 1, 2014

Issued By:

Sean Dandley, CEO/President
303 Wyman Street Suite 350
Waltham, MA, 02451

Change Order Charges

Change Order Charges apply to work associated with providing exchange line service or customer- requested changes to existing services. One charge applies for each change order requested by the customer. If multiple changes listed below are requested by the Customer and occur on the same order/request one charge only applies. A Change Order Service Charge applies to the following customer- initiated changes:

- Service Order Change \$25.00
- Expedited Service Order Change \$50.00
- Advanced Reconfiguration \$75.00
- Expedited Advanced Reconfiguration \$125.00

Printed Invoice Fee

The Company provides local exchange services exclusively to business customers; Company does not provide service to residential customers. All business customers are offered the ability to use electronic/e- mail billing and payment options to manage their relationship with the Company. The Company incurs expenses rendering paper invoices and processing non-electronic payments. The Company therefore will assess a Printed Invoice Fee for those customers who continue to choose the paper invoice/non-electronic payment option.

Printed Invoice Fee	<u>Amount</u>
	\$3.50 per invoice

Intrastate Usage Rates (State of Texas)

<u>Category</u>	<u>Rate per Minute of Use</u>
Local	\$0.069 per minute
IntraLATA	\$0.089 per minute

Issued: August 12, 2014

Effective: September 1, 2014

Issued By:

Sean Dandley, CEO/President
303 Wyman Street Suite 350
Waltham, MA, 02451